

$\phi 12,50$

M8

9

R2

3°

3

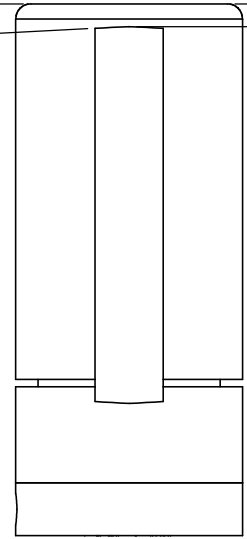
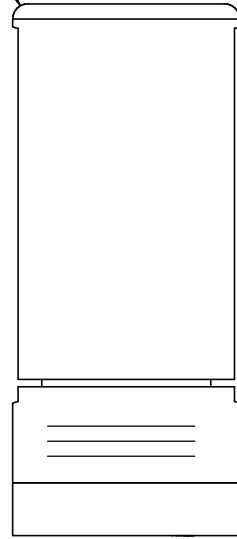
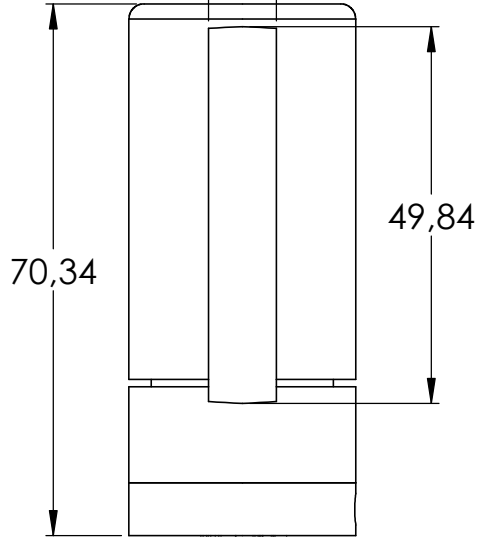
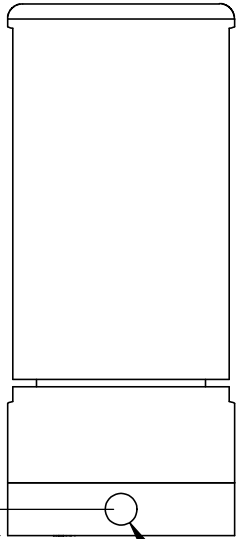

3,50

$\phi 4,20$

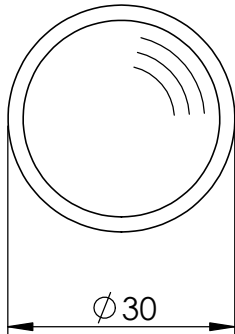

$\phi 30$

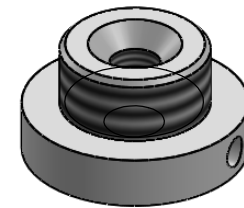
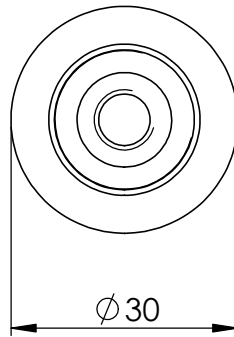
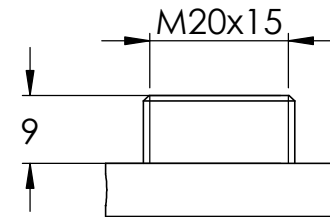
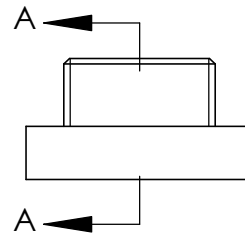
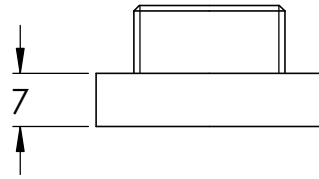
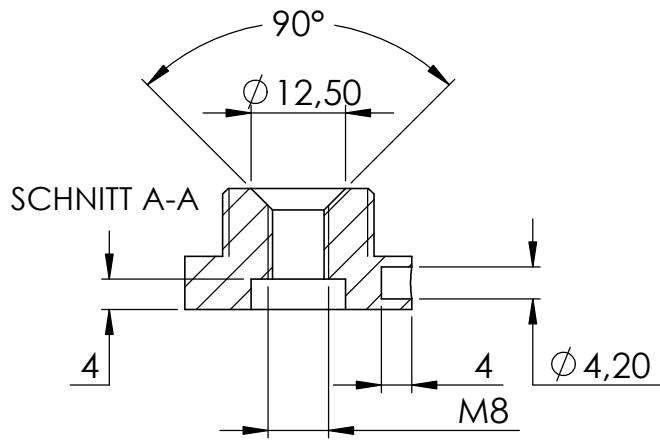
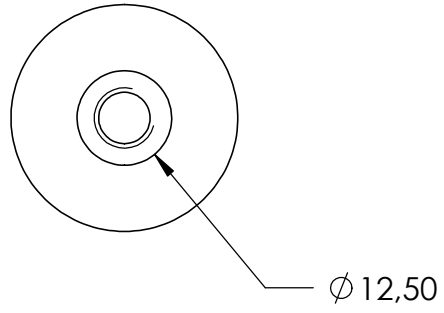

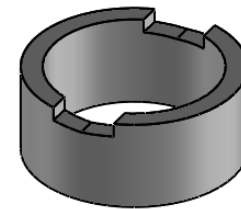
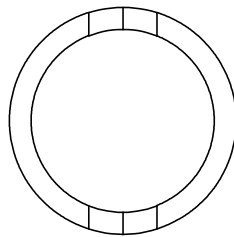
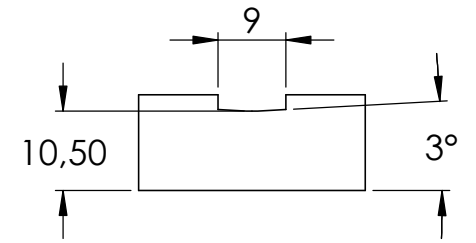
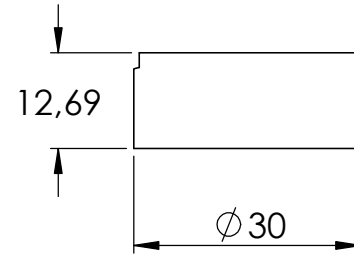
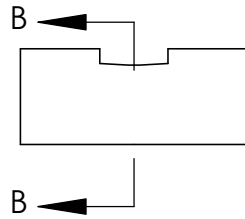
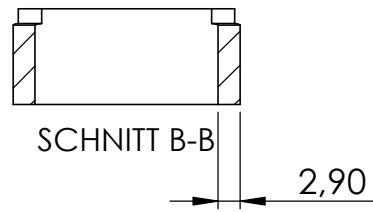
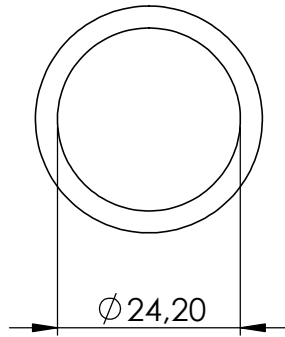

SCHNITT C-C

