

$\phi 42,40$

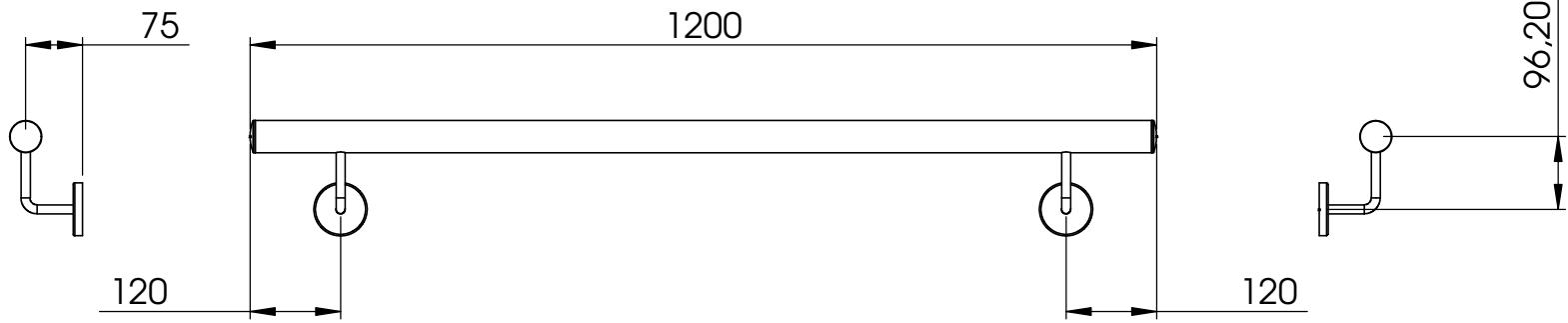

12

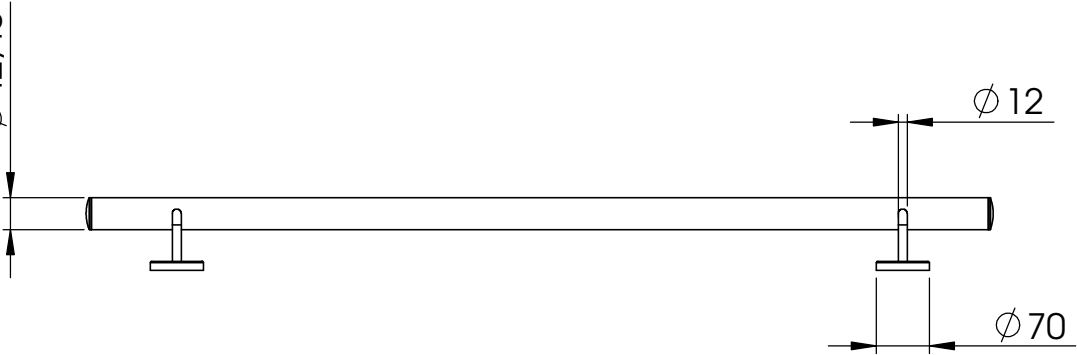

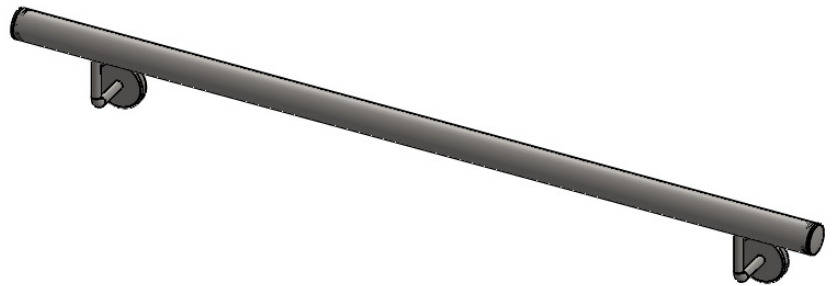
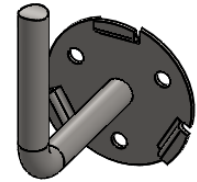
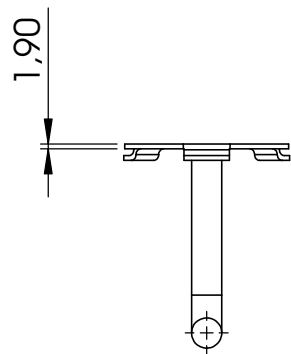
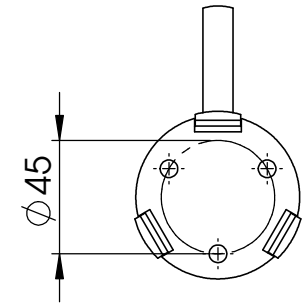
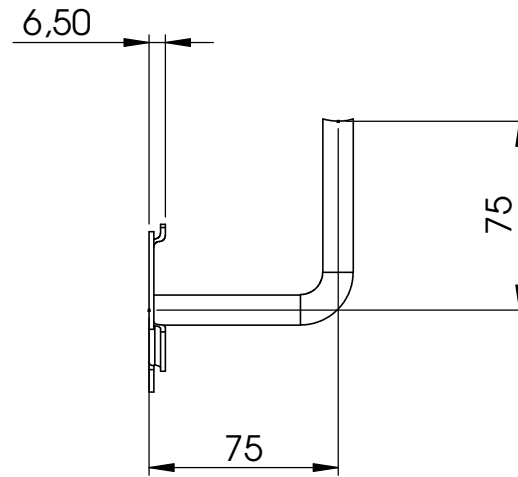
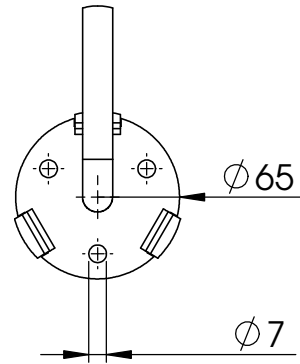
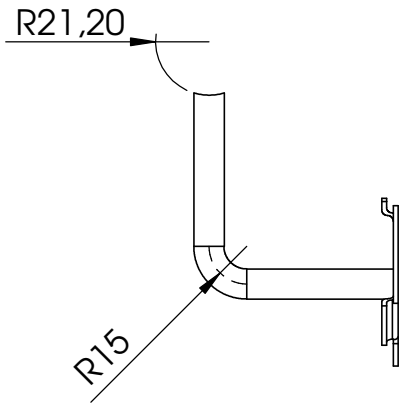
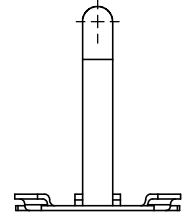

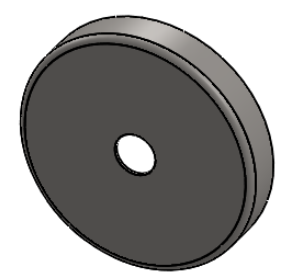
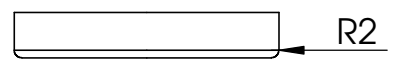
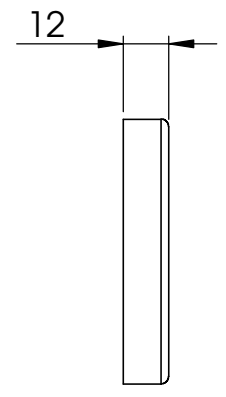
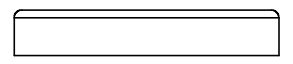
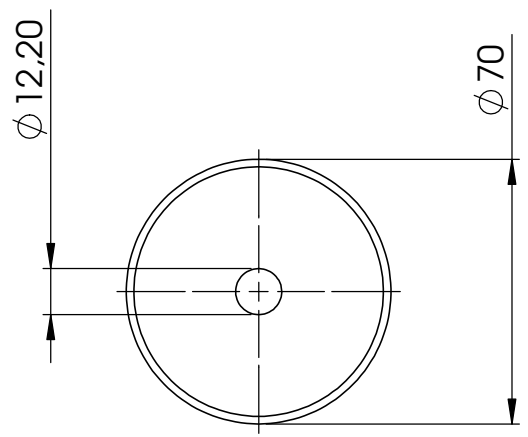
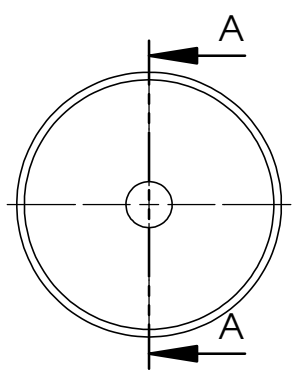
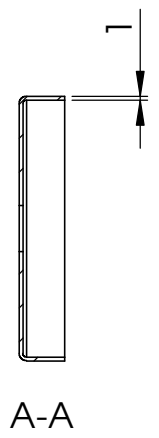

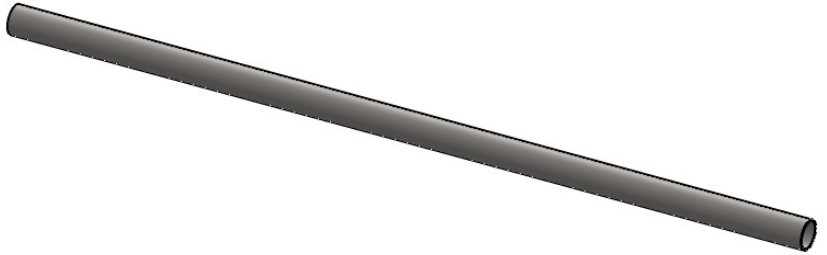
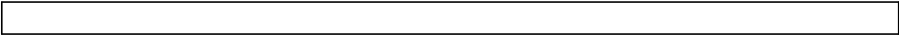
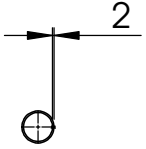
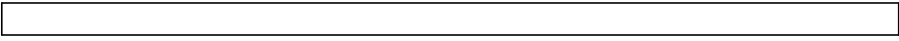
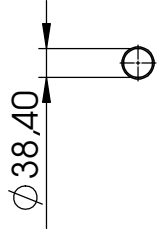
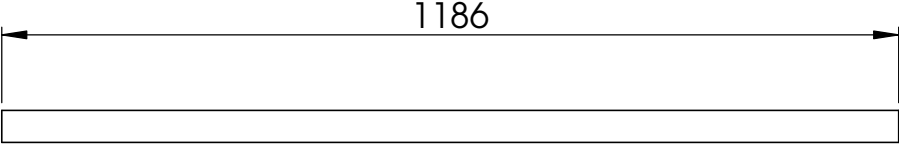

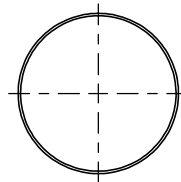
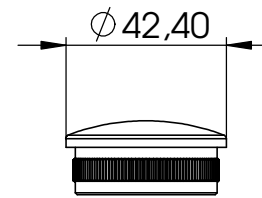
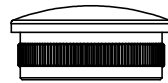
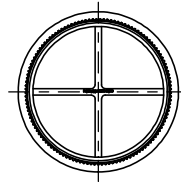
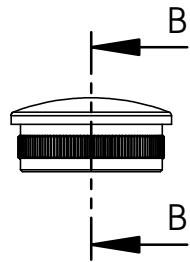
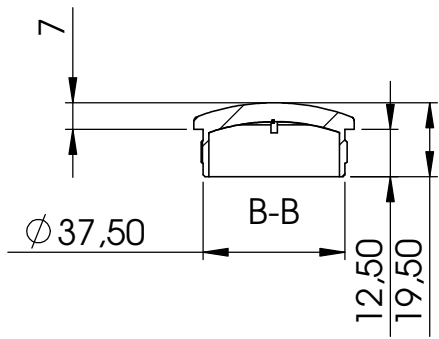

4

57501-240-S Teil2

2

2

1

3

4

