

M10

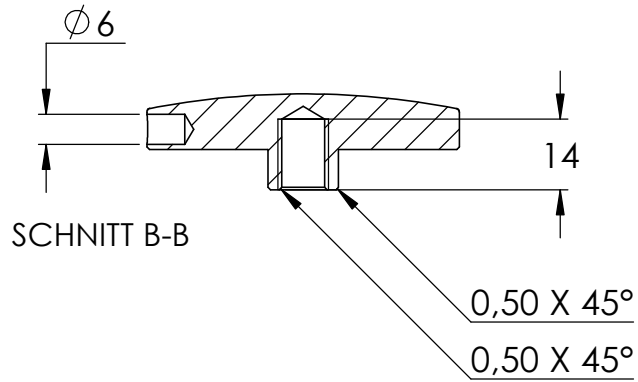

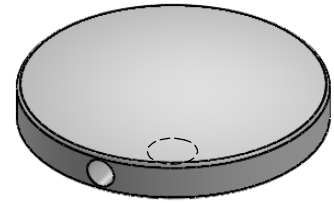

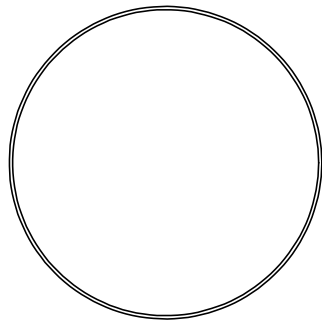

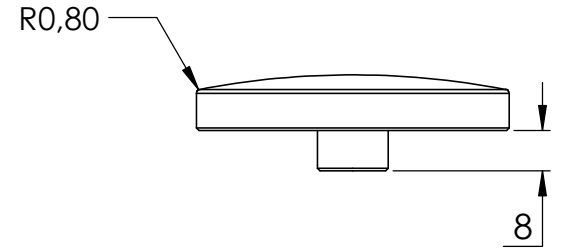
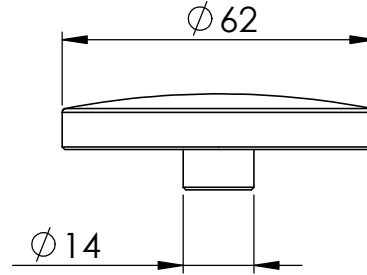
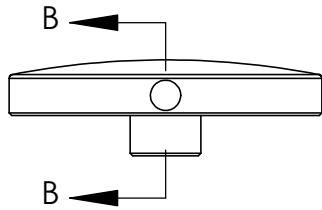
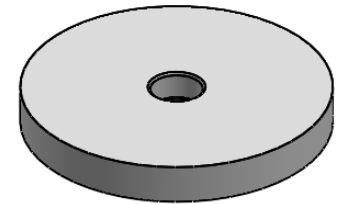
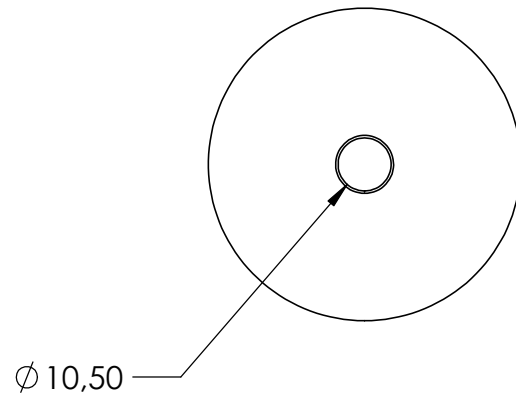
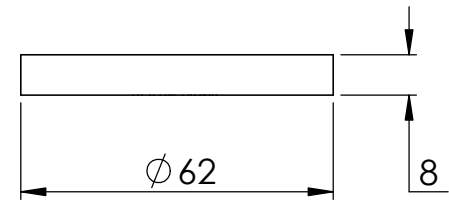
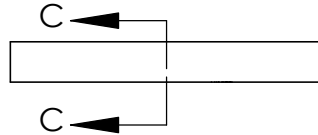
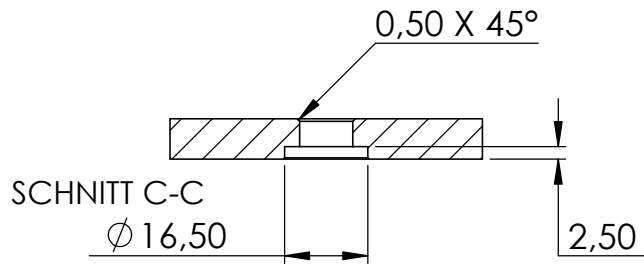
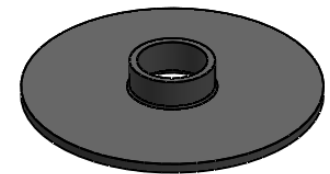
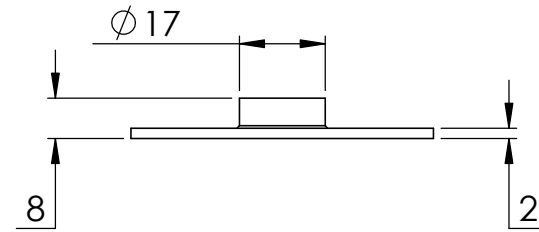
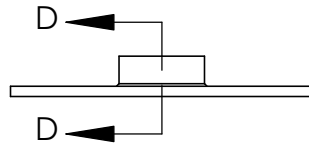
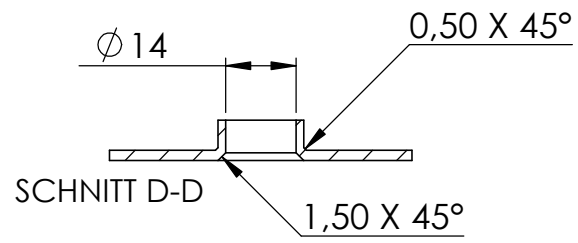
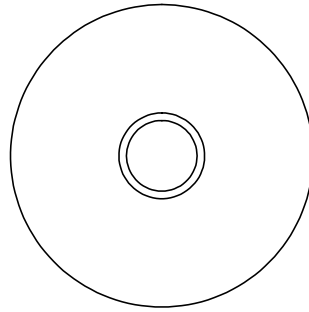
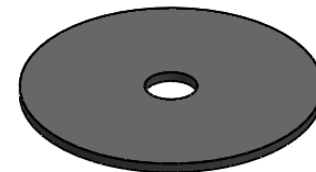
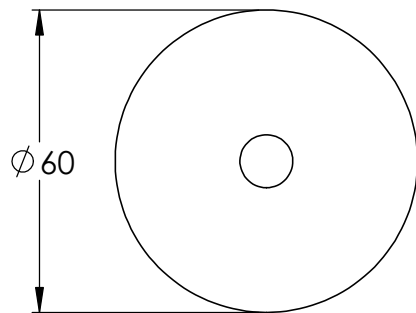
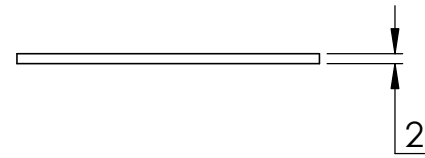
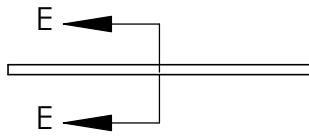
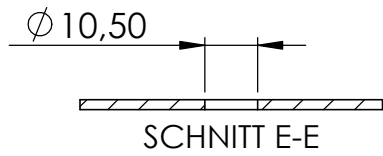
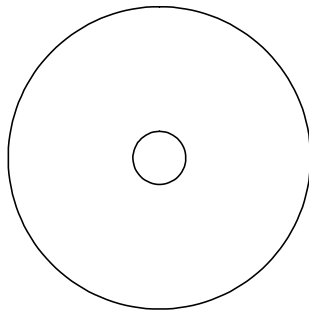

4	60240-240 Teil4	1
5	DIN913 M10x55	1

